



TGM VALUE SERIES AIR HANDLER

Technical Manual

LCAC/2019.5

Content

Part 1. General Information.....	1
1. Nomenclature	2
2. Model Names of Indoor/Outdoor Units	4
3. External Appearance	6
4. Features	7
Part 2. Indoor Unit.....	8
Air Handler Type	8
1. Features	9
2. Specification.....	11
3. Dimension	15
4. Service Space	16
5. Wiring Diagrams.....	18
6. Electric Characteristics	19
7. Exploded View.....	20
8. The Specification of Wiring	22
9. Field Wiring.....	23
10. Trouble shooting	24
Part 3 Outdoor Unit.....	25
1. Specification	26
2. Dimensions	30
3. Service Space.....	31
4. Wiring Diagrams	32
5. Electric Characteristics	33
6. Operation Limits.....	34
7. Sound Levels.....	35
8. Exploded View	36
9. Troubleshooting	40
Part 4 Installation.....	41
1. Precaution on Installation	42
2. Vacuum Dry and Leakage Checking	43
3. Additional Refrigerant Charge	45
4. Insulation Work	46
5. Test Operation.....	48

R410A 60Hz TGM VALUE SERIES AIR HANDLER

Part 1. General Information

1. Nomenclature	2
2. Model Names of Indoor/Outdoor Units	4
3. External Appearance	6
4. Features	7

2. Model Names of Indoor/Outdoor Units

2.1 Indoor Units

Model name	Dimension(W×H×D) (inch)	Power supply
SEER 14 Cooling Only		
CTA14C018A	20 x46 x22	208~230V-1Ph-60Hz
CTA14C024A	20 x46 x22	208~230V-1Ph-60Hz
CTA14C030A	20 x46 x22	208~230V-1Ph-60Hz
CTA14C036A	20 x46 x22	208~230V-1Ph-60Hz
CTA14C042A	20 x46 x22	208~230V-1Ph-60Hz
CTA14C048A	22 x55 x24	208~230V-1Ph-60Hz
CTA14C060A	22 x55 x24	208~230V-1Ph-60Hz

2.2 Outdoor Units

Model name	Dimension (W×H×D) (inch)	Power supply
Cooling Only		
CTV14CN018A	22 x22 x25	208~230V-1Ph-60Hz
CTV14CN018A	22 x22 x25	208~230V-1Ph-60Hz
CTV14CN030A	29 x29 x25	208~230V-1Ph-60Hz
CTV14CN036A	29 x29 x25	208~230V-1Ph-60Hz
CTV14CN042A	29 x29 x33	208~230V-1Ph-60Hz
CTV14CN048A	29 x29 x33	208~230V-1Ph-60Hz
CTV14CN060A	29 x29 x33	208~230V-1Ph-60Hz

3. External Appearance

3.1 Indoor unit



3.2 Outdoor unit



4. Features

4.1 Wide operation range, down to -15 degree for cooling and heating.

4.2 Well known brand fixed compressor, reliable quality.

4.3 Intelligent defrost programs, unit will choose different defrost program according to real condition.

4.4 Condenser coils constructed with copper tubing and enhanced aluminum fins.

4.5 Use TXV as expansion device(14 SEER air handler).

4.6 Direct drive motors, 3-speed, provide selections of air flow to meet desired applications.

4.7 24V control, time delay relay, fan relay and transformer included.

4.8 R410A environment friendly refrigerant.

4.9 AHRI certification, ETL certification.

Part 2. Indoor Unit

Air Handler Type

1. Features	9
2. Specification	11
3. Dimension	15
4. Service Space	16
5. Wiring Diagrams	18
6. Electric Characteristics	19
7. Exploded View	20
8. The Specification of Wiring	22
9. Field Wiring	23
10. Trouble shooting	24

1. Features

(1) "A" shape coils, constructed with copper tubing and enhanced aluminum fins

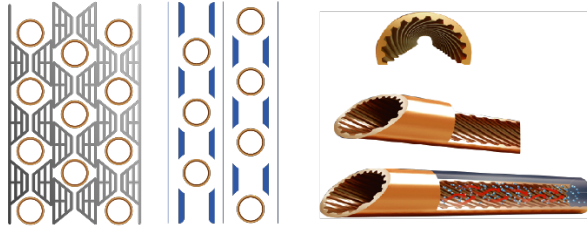

(2) Direct drive motors, 3 speed, provide selections of air flow to meet desired applications.

φ 10" big fan, powerful wind. Motor is covered with thermal insulator, keep motor running in safety status.

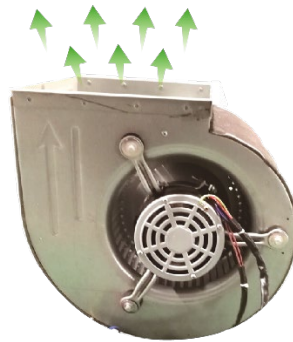

(3) Use TXV as expansion device (14 SEER air handler)



(4) Detachable air filter for cleaning or renewal

Versatile 4-way convertible design for vertical up airflow, horizontal right airflow.

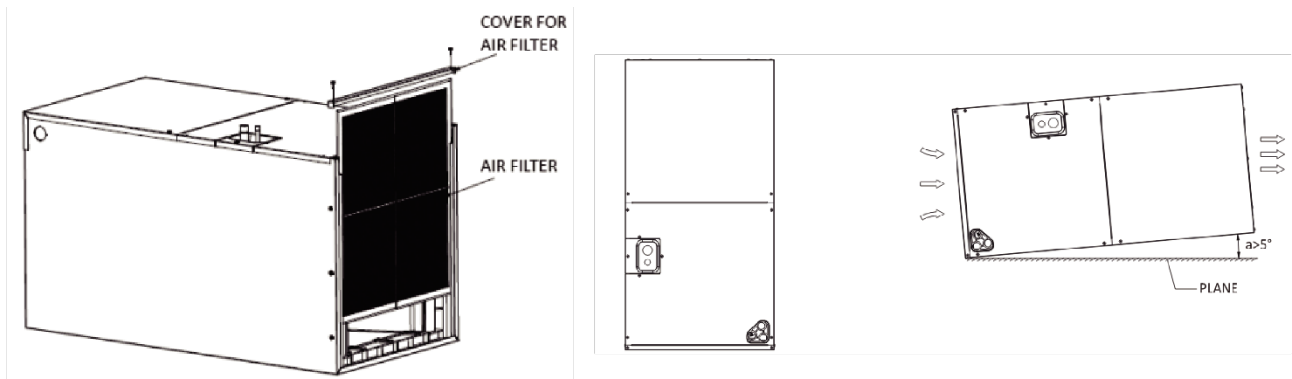

2. Specification

Model			CTA14C018A	CTA14C024A	CTA14C030A
Power supply		V/Ph/Hz	208~230V/1N/60Hz	208~230V/1N/60Hz	208~230V/1N/60Hz
Cooling	Capacity	Btu/h	18000	24000	30000
	SEER	Btu/h.W	14.00	14.00	14.00
Indoor external static pressure		Pa	25	25	37
Throttle type			TXV	TXV	TXV
Indoor coil	Number of row		3(row)×2(piece)	4(row)×2(piece)	4(row)×2(piece)
	Tube pitch(a)×row pitch(b)	in	0.83×0.53	0.83×0.53	0.83×0.53
	Fin spacing	in	1/16	1/16	1/16
	Fin material		Hydrophilic	Hydrophilic	Hydrophilic
	Tube outside diameter	in	Φ 0.276	Φ 0.276	Φ 0.276
	Tube material		inner grooved	inner grooved	inner grooved
	Coil length x height x width	in	17 7/16×14 7/8×1 37/64	17 7/16×16 17/32×2 7/64	17 7/16×16 17/32×2 7/64
	Number of circuit		6	8	8
Indoor fan motor	Brand		Kangbao	Kangbao	Kangbao
	Type		AC	AC	AC
	Input	W	180	206	288
	Output	W	100	135	180
	Capacitor	μF	6	6	6
	Speed (Hi/Me/Lo)	rpm	440/390/340	570/530/490	670/600/530
blower	diameter	in	12 5/16	12 5/16	12 5/16
	width	in	12 29/32	12 29/32	12 29/32
Indoor air flow		CFM	723/610/500	938/804/738	1204/1060/919
Indoor noise level		dB(A)	40	42	48
Indoor dimension	Unit (WxHxD)	in	19.70×45.70×22.05	19.70×45.70×22.05	19.70×45.70×22.05
	Packing (WxHxD)	in	22.40×47.50×24.90	22.40×47.50×24.90	22.40×47.50×24.90

Model			CTA14C036A	CTA14C042A	CTA14C048A	CTA14C060A
Power supply		V/Ph/Hz	208~230V/1N/60Hz	208~230V/1N/60Hz	208~230V/1N/60Hz	208~230V/1N/60Hz
Cooling	Capacity	Btu/h	34500	42000	48000	57000
	SEER	Btu/h. W	14.00	14.00	14.00	14.00
Indoor external static pressure		Pa	37	37	50	50
Throttle type			TXV	TXV	TXV	TXV
Indoor coil	Number of row		4(row)×2(piece)	4(row)×2(piece)	5(row)×2(piece)	5(row)×2(piece)
	Tube pitch(a)×row pitch(b)	in	0.83×0.53	0.83×0.53	0.83×0.53	0.83×0.53
	Fin spacing	in	1/16	1/16	1/16	1/16
	Fin material		Hydrophilic	Hydrophilic	Hydrophilic	Hydrophilic
	Tube outside diameter	in	Φ 0.276	Φ 0.276	Φ 0.276	Φ 0.276
	Tube material		inner grooved	inner grooved	inner grooved	inner grooved
	Coil length x height x width	in	17 7/16×16 17/32×2 7/64	17 7/16×16 17/32×2 7/64	19 27/32×21 1/2×2 5/8	19 27/32×21 1/2×2 5/8
	Number of circuit		8	8	12	12
Indoor fan motor	Brand		Kangbao	Kangbao	Kangbao	Kangbao
	Type		AC	AC	AC	AC
	Input	W	398	463	578	578
	Output	W	220	270	300	300
	Capacitor	μF	10	10	12	12
	Speed (Hi/Me/Lo)	rpm	805/730/690	839/723/610	920/870/820	920/870/820
blower	diameter	in	12 5/16	12 5/16	12 5/16	12 5/16
	width	in	12 29/32	12 29/32	12 29/32	12 29/32
Indoor air flow		CFM	1376/1235/1161	1562/1385/1208	1695/1574/1434	1695/1574/1434
Indoor noise level		dB(A)	51	54	55	55
Indoor dimension	Unit (WxHxD)	in	19.70×45.70×22.05	19.70×45.70×22.05	22.05×53.11×24.45	22.05×53.11×24.45
	Packing (WxHxD)	in	22.40×47.50×24.90	22.40×47.50×24.90	24.80×54.76×27.32	24.80×54.76×27.32

Model		CAHI-18HNR1-14	CAHI-24HNR1-14	CAHI-30HNR1-14
Power supply		V/Ph/Hz	208~230V/1N/60Hz	208~230V/1N/60Hz
Cooling	Capacity	Btu/h	17600	23600
	SEER	Btu/h.W	14.00	14.00
Indoor external static pressure		Pa	25	37
Throttle type			TXV	TXV
Indoor coil	Number of row		3(row)×2(piece)	4(row)×2(piece)
	Tube pitch(a)×row pitch(b)	in	0.83×0.53	0.83×0.53
	Fin spacing	in	1/16	1/16
	Fin material		Hydrophilic	Hydrophilic
	Tube outside diameter	in	Φ 0.276	Φ 0.276
	Tube material		inner grooved	inner grooved
	Coil length x height x width	in	17 7/16×14 7/8×1 37/64	17 7/16×16 17/32×2 7/64
Number of circuit			6	8
Indoor fan motor	Brand		Kangbao	Kangbao
	Type		AC	AC
	Input	W	180	206
	Output	W	100	135
	Capacitor	μF	6	6
Speed (Hi/Me/Lo)		rpm	440/390/340	570/530/490
blower	diameter	in	12 5/16	12 5/16
	width	in	12 29/32	12 29/32
Indoor air flow		CFM	723/610/500	938/804/738
Indoor noise level		dB(A)	39	41
Indoor dimension	Unit (W×H×D)	in	19.70×45.70×22.05	19.70×45.70×22.05
	Packing (W×H×D)	in	22.40×47.50×24.90	22.40×47.50×24.90

Model			CAHI-36HNR1-14	CAHI-42HNR1-14	CAHI-48HNR1-14	CAHI-60HNR1-14
Power supply		V/Ph/Hz	208~230V/1N/60Hz	208~230V/1N/60Hz	208~230V/1N/60Hz	208~230V/1N/60Hz
Cooling	Capacity	Btu/h	34000	40500	46000	57000
	SEER	Btu/h.W	14.00	14.00	14.00	14.00
Indoor external static pressure		Pa	37	37	50	50
Throttle type			TXV	TXV	TXV	TXV
Indoor coil	Number of row		4(row)×2(piece)	4(row)×2(piece)	5(row)×2(piece)	5(row)×2(piece)
	Tube pitch(a)×row pitch(b)	in	0.83×0.53	0.83×0.53	0.83×0.53	0.83×0.53
	Fin spacing	in	1/16	1/16	1/16	1/16
	Fin material		Hydrophilic	Hydrophilic	Hydrophilic	Hydrophilic
	Tube outside diameter	in	Φ 0.276	Φ 0.276	Φ 0.276	Φ 0.276
	Tube material		inner grooved	inner grooved	inner grooved	inner grooved
	Coil length x height x width	in	17 7/16×16 17/32×2 7/64	17 7/16×16 17/32×2 7/64	19 27/32×21 1/2×2 5/8	19 27/32×21 1/2×2 5/8
	Number of circuit		8	8	12	12
Indoor fan motor	Brand		Kangbao	Kangbao	Kangbao	Kangbao
	Type		AC	AC	AC	AC
	Input	W	398	463	578	578
	Output	W	220	270	300	400
	Capacitor	μF	10	10	12	12
	Speed (Hi/Me/Lo)	rpm	805/730/690	839/723/610	920/870/820	920/870/820
blower	diameter	in	12 5/16	12 5/16	12 5/16	12 5/16
	width	in	12 29/32	12 29/32	12 29/32	12 29/32
Indoor air flow		CFM	1376/1235/1161	1562/1385/1208	1695/1574/1434	1695/1574/1434
Indoor noise level		dB(A)	51	53	55	55
Indoor dimension	Unit (WxHxD)	in	19.70×45.70×22.05	19.70×45.70×22.05	22.05×53.11×24.45	22.05×53.11×24.45
	Packing (WxHxD)	in	22.40×47.50×24.90	22.40×47.50×24.90	24.80×54.76×27.32	24.80×54.76×27.32

Notes:

- Nominal cooling capacities are based on the following conditions:
Indoor temp: 27°CDB, 19°CWB; Outdoor temp: 35°CDB; Equivalent ref. piping: 5m (horizontal)
- Nominal heating capacities are based on the following conditions:
Indoor temp: 20°CDB; Outdoor temp: 7°CDB, 6°CWB; Equivalent ref. piping: 5m (horizontal)
- Actual noise level may differ, depending on the room structure, etc., since these noise values are from an anechoic room.

3. Dimension

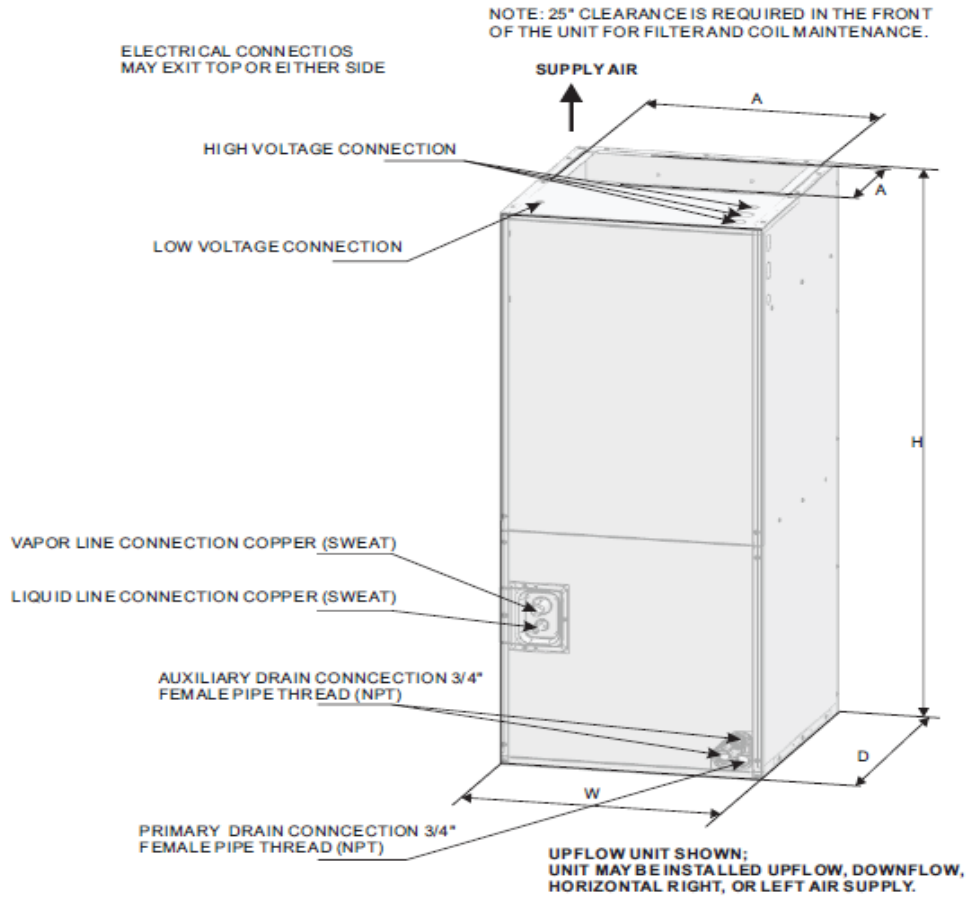

DIMENSIONAL DATA

Fig.1 DIMENSIONS

MODEL SIZE	Dimensions				
	UNIT HEIGHT "H" /mm	UNIT WIDTH "W" /mm	UNIT LENGHT "D" /mm	SUPPLY DUCT"A" /mm	LIQUID LINE/ VAPOR LINE IN
18K	1163	500	560	454	3/8" / 7/8"
24K	1163	500	560	454	3/8" / 7/8"
30K	1163	500	560	454	3/8" / 7/8"
36K	1163	500	560	454	3/8" / 7/8"
42K	1163	500	560	454	3/8" / 7/8"
48K	1350	560	622	496	3/8" / 7/8"
60K	1350	560	622	496	3/8" / 7/8"

4. Service Space

The indoor unit should be installed in a location that meets the following requirements:
INSTALLATION NOTES: .

1. When up hand discharge , how to trap or plug all drains is see the left Figure.
2. When right hand discharge , how to trap or plug all drains is see the top Figure.
3. The seal-plugs are supplied as accessories , and be screwed tightly only with hand.

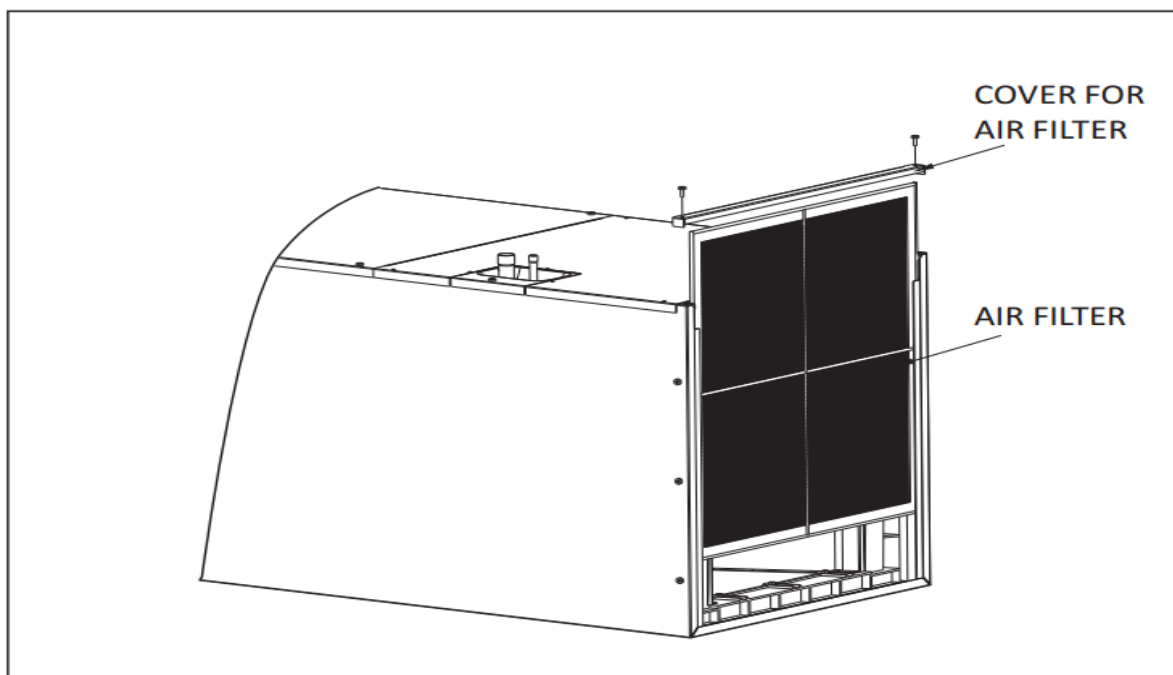
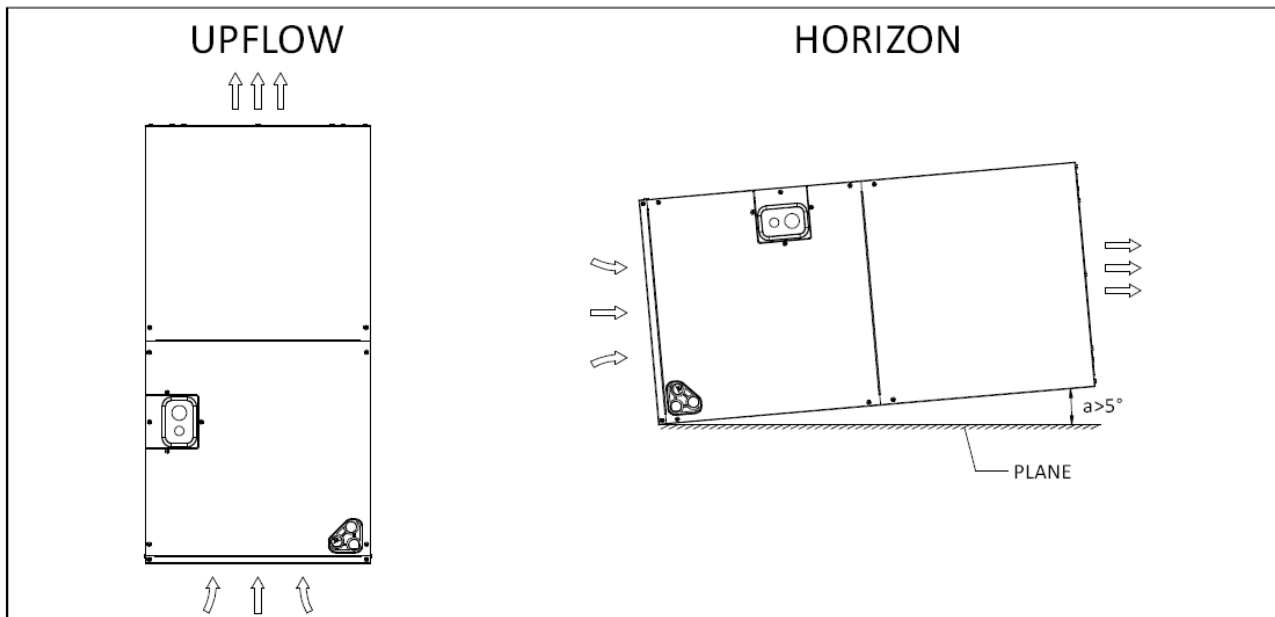

5. Wiring Diagrams

18K/24K/30K/36K/42K

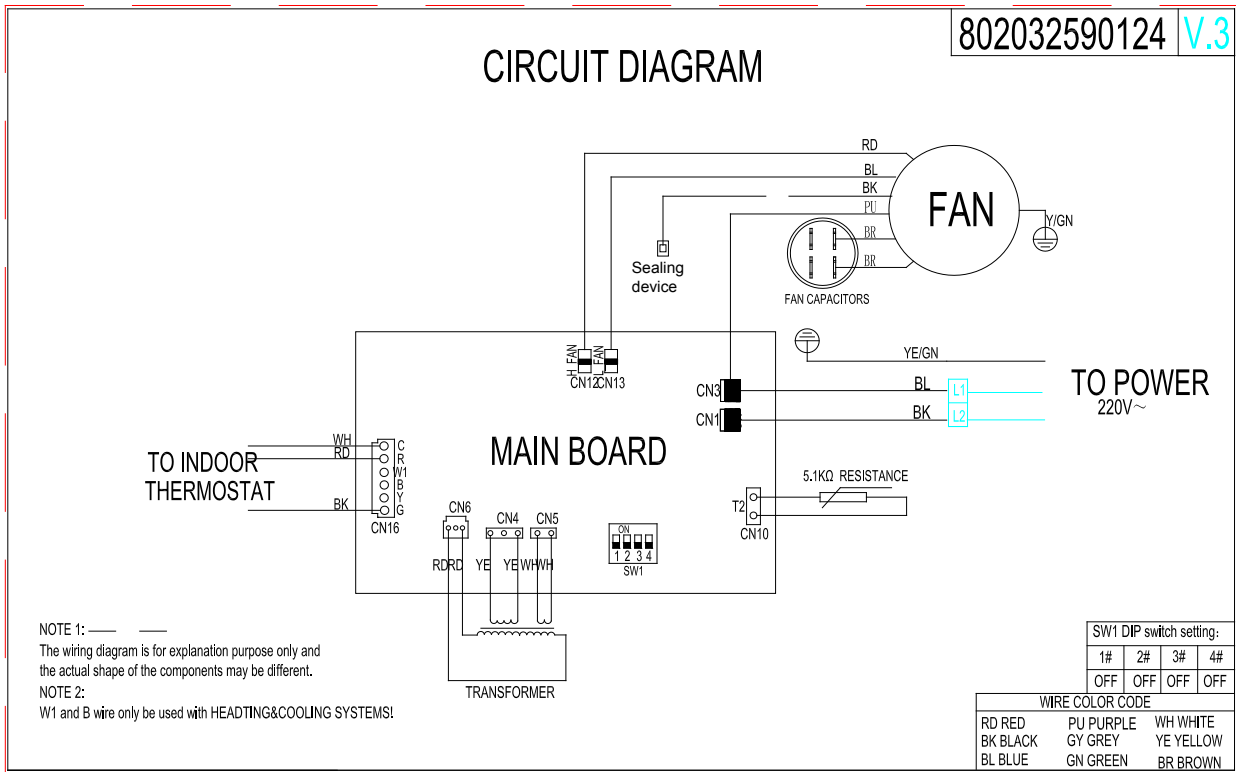

48K

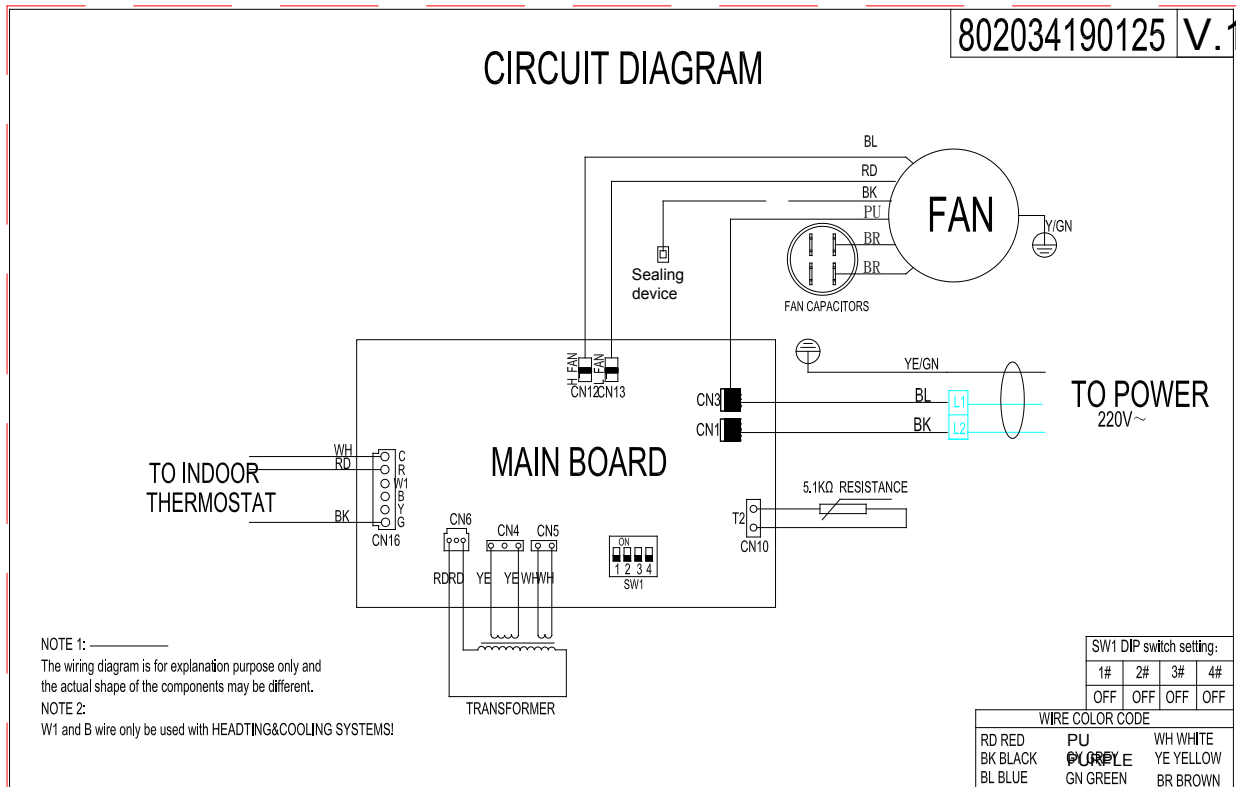

CIRCUIT DIAGRAM

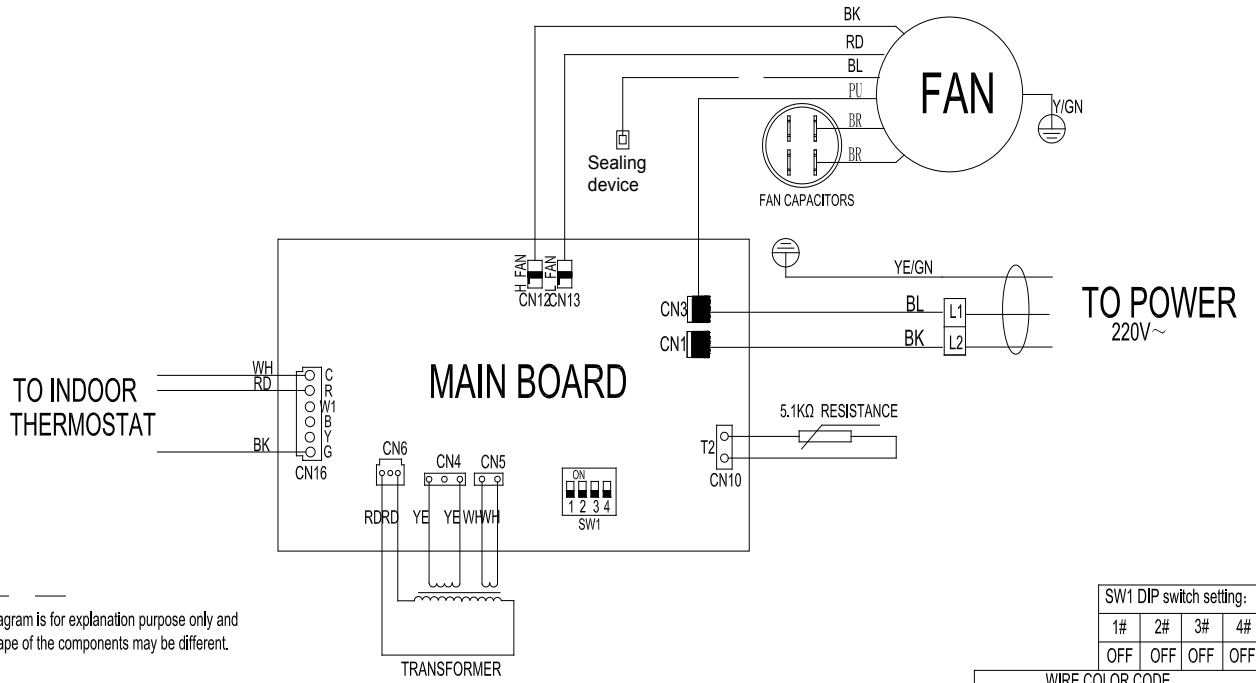

NOTE 1: _____
 The wiring diagram is for explanation purpose only and the actual shape of the components may be different.

SW1 DIP switch setting:			
1#	2#	3#	4#
OFF	OFF	OFF	OFF

WIRE COLOR CODE		
RD RED	PU PURPLE	WH WHITE
BK BLACK	OR ORANGE	YE YELLOW
BL BLUE	GN GREEN	BR BROWN

6. Electric Characteristics

Model	Indoor Units				Indoor Fan Motor
	Hz	Voltage	Min.	Max.	kW
SEER 14 Cooling Only					
CTA14C018A	60	208-230V	198V	242V	0.18
CTA14C024A	60	208-230V	198V	242V	0.21
CTA14C030A	60	208-230V	198V	242V	0.29
CTA14C036A	60	208-230V	198V	242V	0.40
CTA14C042A	60	208-230V	198V	242V	0.46
CTA14C048A	60	208-230V	198V	242V	0.58
CTA14C060A	60	208-230V	198V	242V	0.58
SEER 14 Heat Pump					
CAHI-18HNR1-14	60	208-230V	198V	242V	0.18
CAHI-24HNR1-14	60	208-230V	198V	242V	0.21
CAHI-30HNR1-14	60	208-230V	198V	242V	0.29
CAHI-36HNR1-14	60	208-230V	198V	242V	0.40
CAHI-42HNR1-14	60	208-230V	198V	242V	0.46
CAHI-48HNR1-14	60	208-230V	198V	242V	0.58
CAHI-60HNR1-14	60	208-230V	198V	242V	0.58

7. Exploded View

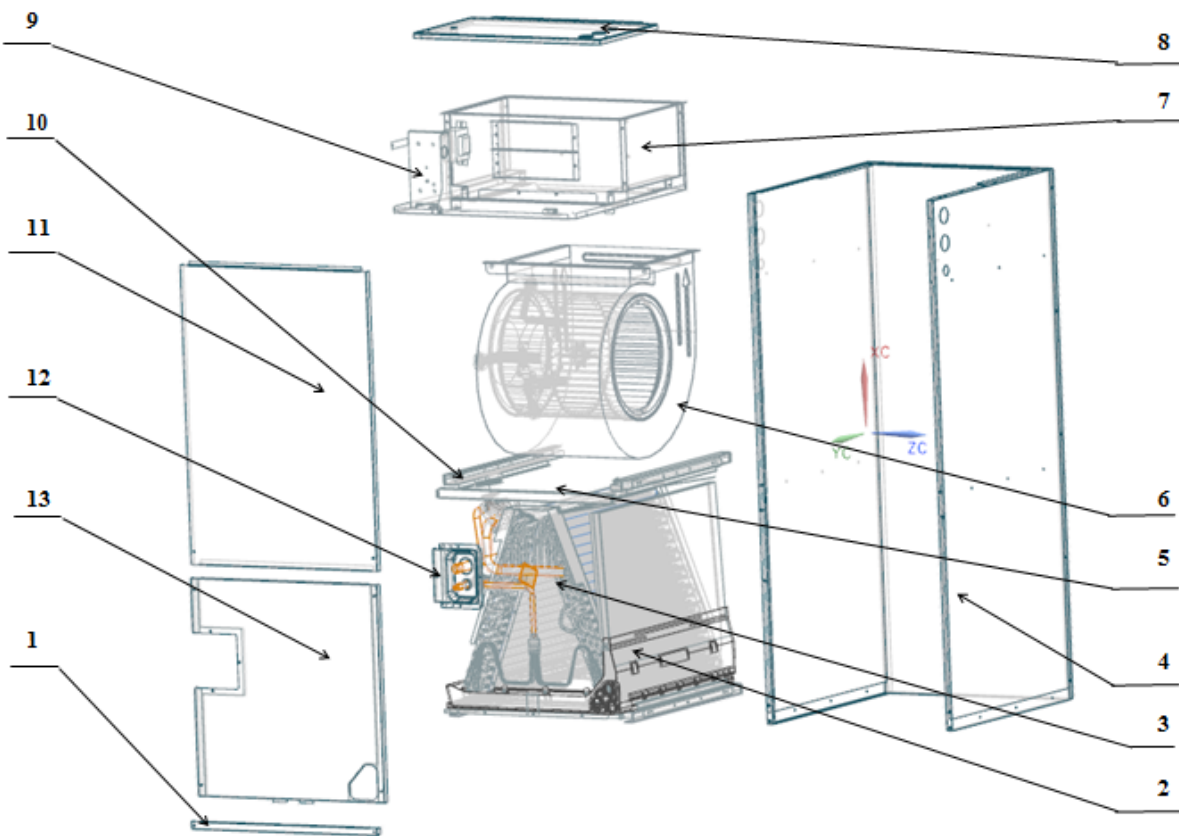

No.	Part Name	Quantity
1	Filter Cover plate	1
2	Water pan components	1
2.1	Water pan# 1	1
2.2	Water pan# 2	1
2.3	Water pan fixed block	1
2.4	Water pan brace	2
3	Evaporator pre-welded assembly	1
3.1	Air header Assembly	1
3.2	Diverter Assembly	1
3.3	Evaporator	2
3.4	Evaporator Baffle	1
3.5	Evaporator Baffle	1
3.6	Evaporator Water Baffle #1	2
3.7	Evaporator Water Baffle #2	1

3.8	Evaporator Water Baffle #3	1
3.9	Evaporator Fixing Plate #1	1
3.10	Evaporator Fixing Plate #2	1
3.11	Evaporator Junction Plate	1
4	Chasiss assembly	1
5	Supporter	2
6.1	Right Volute Wind Wheel	1
6.2	Indoor Motor	1
7	Fan Motor Fixing plate assembly	1
7.1	Fan Motor Fixing plate	1
7.2	Wind Wheel Fixed Block	2
7.3	Fixed plate on air duct	1
7.4	Stator	2
7.5	air duct left stationary plate	1
7.6	air duct right stationary plate	1
8	Electronically Controlled Cover Plate Cotton Pasting Component	1
9	Electronic Control Components	1
9.1	Electronic Control Mounting Plate	1
9.2	Main Board	1
9.3	Transformer	1
10	Water pan supporter assembly	4
11	Upper side plate assembly	1
12	Pipe Cover plate assembly	1
13	Lower side plate assembly	1

8. The Specification of Wiring

Note:

The cross-section areas of wires or lines should not be less than the corresponding ones listed in the table below; Besides, if the power wires is quite long from the unit, please choose the windings with larger cross-section area to guarantee the normal power supply.

Model	Type	Indoor power wirress	Thermostat communication wirress		Outdoor power wirress
			Indoor	Outdoor	
18 K series (single phase)	Cooling only	3*1.0mm ²	3*0.75mm ²	2*0.75mm ²	3*1.0mm ²
	Cooling & heating		4*0.75mm ²	3*0.75mm ²	
24 K series (single phase)	Cooling only		3*0.75mm ²	2*0.75mm ²	3*2.5mm ²
	Cooling & heating		4*0.75mm ²	3*0.75mm ²	
30 K series (single phase)	Cooling only		3*0.75mm ²	2*0.75mm ²	
	Cooling & heating		4*0.75mm ²	3*0.75mm ²	
36 K series (single phase)	Cooling only		3*0.75mm ²	2*0.75mm ²	
	Cooling & heating		4*0.75mm ²	3*0.75mm ²	
42 K series (single phase)	Cooling only		3*0.75mm ²	2*0.75mm ²	3*4mm ²
	Cooling & heating		4*0.75mm ²	3*0.75mm ²	
48 K series (single phase)	Cooling only		3*0.75mm ²	2*0.75mm ²	
	Cooling & heating		4*0.75mm ²	3*0.75mm ²	
60 K series (single phase)	Cooling only		3*0.75mm ²	2*0.75mm ²	
	Cooling & heating		4*0.75mm ²	3*0.75mm ²	

9. Field Wiring

1. To avoid the electrical shock, please connect the air conditioner with the ground lug. The main power plug in the air conditioner has been joined with the ground wiring, please don't change it freely.
2. The power socket is used as the air conditioner specially.
3. Don't pull the power wiring hard.
4. When connecting the air conditioner with the ground, observe the local codes.
5. If necessary, use the power fuse or the circuit, breaker or the corresponding scale ampere.

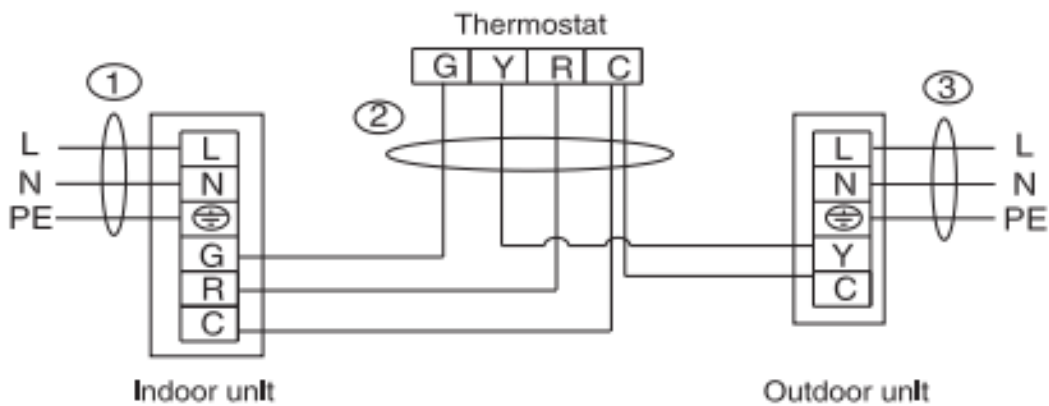

Applicable for 18k, 24k, 30k, 36k, 42k, 48k, 60k cooling only type

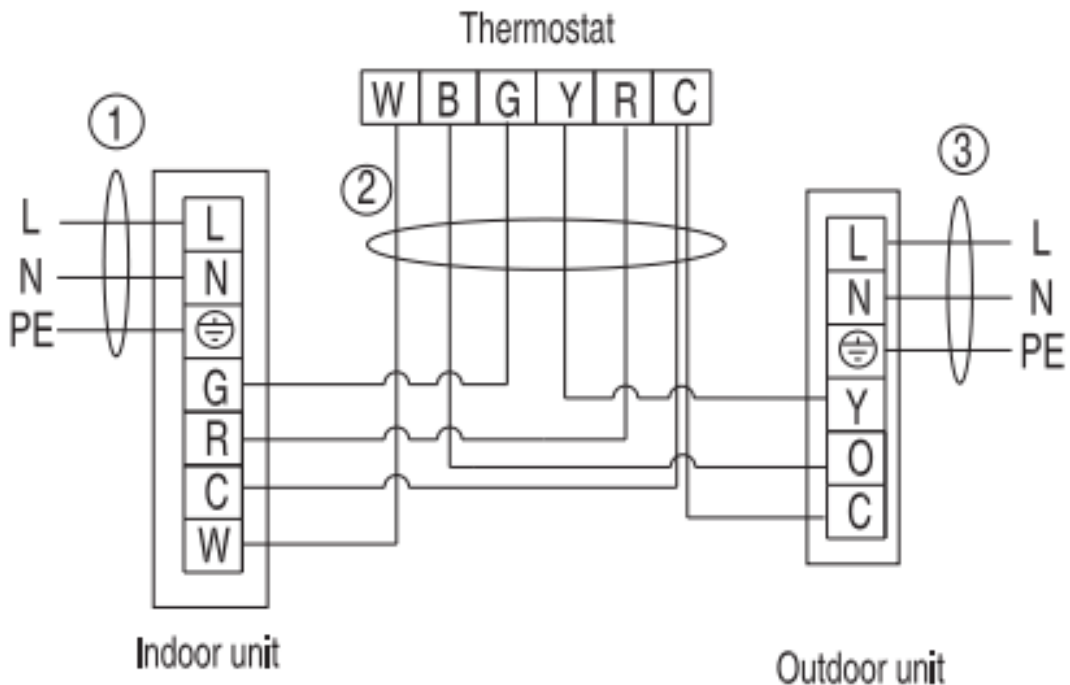

Applicable for 18k, 24k, 30k, 36k, 42k, 48k, 60k cooling & heating type

10. Troubleshooting

The fault codes for indoor unit as follows:

Display mode	Status description
Green light always on	No system alarm and error, normal standby
Red light always on	Evaporator tube temperature sensor(T 2) failure
Green light always on, yellow light flashing	Evaporator high and low temperature protection
Green light flashing	system is in normal operating status

Part 3 Outdoor Unit

1. Specification	26
2. Dimensions.....	30
3. Service Space	31
4. Wiring Diagrams	32
5. Electric Characteristics	33
6. Operation Limits	34
7. Sound Levels.....	35
8. Exploded View.....	36
9. Troubleshooting.....	40

1. Specification

Model			COT-18CNR1	COT-24CNR1	COT-30CNR1	COT-36CNR1
Outdoor power supply		V/Ph/Hz	230V/1N/60HZ	230V/1N/60HZ	230V/1N/60HZ	230V/1N/60HZ
Cooling	Capacity	Btu/h	18000	24000	30000	34500
	Input	W	1530	2040	2570	2930
	EER	Btu/h.W	11.70	11.70	11.60	11.70
	SEER (AHRI Certified)	Btu/h.W	14	14	14	14
heating	Capacity	Btu/h	—	—	—	—
	HSPF (AHRI Certified)	Btu/h.W	—	—	—	—
Max. input consumption		W	1912.50	2550.00	3212.50	3662.50
Max. current		A	8.75	11.67	14.70	16.76
Compressor	Brand		HITACHI	HITACHI	HITACHI	HITACHI
	Model		ASL145DG-C7EU	ASH201DG-C8LU1L	ASH250DG-C8DU	ASH280DG-C8DU
	Type		rotary	rotary	rotary	rotary
	Capacity	W	4240	5970	7350	8260
	Input	W	1390	1950	2410	2700
	Rated current(RLA)	A	6.10	8.7	10.7	11.9
	Locked rotor Amp(LRA)	A	33	44	56	60
	Thermal protector	uf	40	40	60	70
Refrigerant oil	ml	480	570	570	570	
Outdoor fan motor	Brand		chigo	chigo	chigo	chigo
	Model		S.TB-DQ-YDK-60-6P 2-AL	S.TB-DQ-YDK-85-6P 2-AL	S.TB-DQ-YDK-110-8 P2-AL	S.TB-DQ-YDK-110-8 P2-AL
	Input	W	145	178	207	207
	Output	W	60	85	110	110
	Capacitor	μF	6.00	6.00	6.00	6.00
	Speed	rpm	870	970	850	850
Outdoor coil	Number of row		1	2	1	2
	Fin spacing	in	0.055	0.055	0.055	0.055
	Fin material		non-Hydrophilic Aluminium Fin	non-Hydrophilic Aluminium Fin	non-Hydrophilic Aluminium Fin	non-Hydrophilic Aluminium Fin
	Tube outside diameter	in	Φ 0.276	Φ 0.276	Φ 0.276	Φ 0.276
	Tube material		Inner Grooved	Inner Grooved	Inner Grooved	Inner Grooved
	Coil length x height x width	in	56.22×23.15×0.53	56.22×23.15×1.05	84.65×23.15×0.53	84.65×23.15×1.05
	Number of circuit		3	4	4	6
Outdoor air flow		CFM	723/610/500	938/804/738	1204/1060/919	1376/1235/1161
Outdoor noise level		dB(A)	57	60	60	60
Outdoor dimension	Unit (WxHxD)	in	22×22×25	22×22×25	29×29×25	29×29×25
	Packing (WxHxD)	in	23×23×26	23×23×26	30×30×26	30×30×26
Refrigerant	Type		R410A	R410A	R410A	R410A
	Charge	ozs	70.55	93.47	89.95	123.46
Refrigerant pipe	Liquid side	in	Φ3/8	Φ3/8	Φ3/8	Φ3/8
	Gas side	in	Φ5/8	Φ5/8	Φ5/8	Φ3/4
	Max. refrigerant pipe length	ft	65 3964	65 3964	65 3964	65 3964
	Max. difference in level	ft	32 13/16	32 13/16	32 13/16	32 13/16
Design pressure		MPa	4.0/1.2	4.0/1.2	4.0/1.2	4.0/1.2
Max pressure		MPa	4.20	4.20	4.20	4.20

Model			COT-42CNR1	COT-48CNR1	COT-60CNR1
Outdoor power supply		V/Ph/H z	230V/1N/60HZ	230V/1N/60HZ	230V/1N/60HZ
Cooling	Capacity	Btu/h	42000	48000	57000
	Input	W	3570	4088	4920
	EER	Btu/h. W	11.70	11.70	11.40
	SEER (AHRI Certified)	Btu/h. W	14	14	14
heating	Capacity	Btu/h	—	—	—
	HSPF (AHRI Certified)	Btu/h. W	—	—	—
Max. input consumption		W	4462.50	5110.00	6150.00
Max. current		A	20.42	23.39	28.15
Compressor	Brand		LG	LG	LG
	Model		ABG036KAC	ABG042KAC	ABG051KAC
	Type		scroll	scroll	scroll
	Capacity	W	10551	12309	14974
	Input	W	3429	3962	4722
	Rated current(RLA)	A	15.2	17.3	21.0
	Locked rotor Amp(LRA)	A	112	108	128
	Thermal protector	uf	45	70	70
Refrigerant oil	ml	1280	1280	1280	
Outdoor fan motor	Brand		chigo	xinjun	xinjun
	Model		S.TB-DQ-YDK-110-8P2-A L	S.TB-DQ-YDK-230-6P2	S.TB-DQ-YDK-230-6P2
	Input	W	207	510	510
	Output	W	110	230	230
	Capacitor	μF	6.00	12.00	12.00
	Speed	rpm	850	1095	1095
Outdoor coil	Number of row		2	2	2.7
	Fin spacing	in	0.055	0.055	0.055
	Fin material		non-Hydrophilic Aluminium Fin	non-Hydrophilic Aluminium Fin	non-Hydrophilic Aluminium Fin
	Tube outside diameter	in	Φ 0.276	Φ 0.276	Φ 0.276
	Tube material		Inner Grooved	Inner Grooved	Inner Grooved
	Coil length x height x width	in	84.65×31.48×1.05	84.65×31.48×1.05	84.65×31.48×1.05
	Number of circuit		8	8	8
Outdoor air flow		CFM	1562/1385/1208	1695/1574/1434	1695/1574/1434
Outdoor noise level		dB(A)	60	63	63
Outdoor dimension	Unit (WxHxD)	in	29×29×33	29×29×33	29×29×33
	Packing (WxHxD)	in	30×30×34	30×30×34	30×30×34
Refrigerant	Type		R410A	R410A	R410A
	Charge	ozs	148.15	148.15	178.13
Refrigerant pipe	Liquid side	in	Φ3/8	Φ3/8	Φ3/8
	Gas side	in	Φ3/4	Φ3/4	Φ7/8
	Max. refrigerant pipe length	ft	65 3964	65 3964	65 3964
	Max. difference in level	ft	32 13/16	32 13/16	32 13/16
Design pressure		MPa	4.0/1.2	4.0/1.2	4.0/1.2
Max pressure		MPa	4.20	4.20	4.20

Model		COT-18HNR1	COT-24HNR1	COT-30HNR1	COT-36HNR1	
Outdoor power supply		V/Ph/Hz	230V/1N/60HZ	230V/1N/60HZ	230V/1N/60HZ	230V/1N/60HZ
Cooling	Capacity	Btu/h	17600	23600	28600	34000
	Input	W	1530	2052	2600	2931
	EER	Btu/h. W	11.50	11.50	10.90	11.60
	SEER (AHRI Certified)	Btu/h. W	14	14	14	14
heating	Capacity	Btu/h	17200.00	22200.00	28600.00	33500.00
	HSPF (AHRI Certified)	Btu/h. W	8.20	8.20	8.30	8.30
Max. input consumption		W	1912.50	2565.00	3250.00	3663.75
Max. current		A	8.75	11.74	14.87	16.77
Compressor	Brand		HITACHI	HITACHI	HITACHI	HITACHI
	Model		ASL145DG-C7EU	ASH201DG-C8LU1 L	ASH250DG-C8DU	ASH280DG-C8DU
	Type		rotary	rotary	rotary	rotary
	Capacity	W	4240	5970	7350	8260
	Input	W	1390	1950	2410	2700
	Rated current(RLA)	A	6.10	8.7	10.7	11.9
	Locked rotor Amp(LRA)	A	33	44	56	60
	Thermal protector	uf	40	40	60	70
	Refrigerant oil	ml	480	570	570	570
Outdoor fan motor	Brand		chigo	chigo	chigo	chigo
	Model		S.TB-DQ-YDK-60-6 P2-AL	S.TB-DQ-YDK-85-6 P2-AL	S.TB-DQ-YDK-110-8 P2-AL	S.TB-DQ-YDK-110-8 P2-AL
	Input	W	145	178	207	207
	Output	W	60	85	110	110
	Capacitor	µF	6.00	6.00	6.00	6.00
	Speed	rpm	870	970	850	850
Outdoor coil	Number of row		1	2	1	2
	Fin spacing	in	0.055	0.055	0.055	0.055
	Fin material		Hydrophilic Aluminium Fin	Hydrophilic Aluminium Fin	Hydrophilic Aluminium Fin	Hydrophilic Aluminium Fin
	Tube outside diameter	in	Φ 0.276	Φ 0.276	Φ 0.276	Φ 0.276
	Tube material		Inner Grooved	Inner Grooved	Inner Grooved	Inner Grooved
	Coil length x height x width	in	56.22×23.15×0.53	56.22×23.15×1.05	84.65×23.15×0.53	84.65×23.15×1.05
	Number of circuit		3	6	4	6
Outdoor air flow		CFM	723/610/500	938/804/738	1204/1060/919	1376/1235/1161
Outdoor noise level		dB(A)	60	60	61	61
Outdoor dimension	Unit (WxHxD)	in	22×22×25	22×22×25	29×29×25	29×29×25
	Packing (WxHxD)	in	23×23×26	23×23×26	30×30×26	30×30×26
Refrigerant	Type		R410A	R410A	R410A	R410A
	Charge	ozs	70.55	95.24	89.95	123.46
Refrigerant pipe	Liquid side	in	Φ3/8	Φ3/8	Φ3/8	Φ3/8
	Gas side	in	Φ5/8	Φ5/8	Φ5/8	Φ3/4
	Max. refrigerant pipe length	ft	65 39/64	65 39/64	65 39/64	65 39/64
	Max. difference in level	ft	32 13/16	32 13/16	32 13/16	32 13/16
Design pressure		MPa	4.0/1.2	4.0/1.2	4.0/1.2	4.0/1.2
Max pressure		MPa	4.20	4.20	4.20	4.20

Model			COT-42HNR1	COT-48HNR1	COT-60HNR1
Outdoor power supply		V/Ph/H z	230V/1N/60HZ	230V/1N/60HZ	230V/1N/60HZ
Cooling	Capacity	Btu/h	40500	46000	57000
	Input	W	3584	4035	5327
	EER	Btu/h. W	11.30	11.40	11.20
	SEER (AHRI Certified)	Btu/h. W	14	14	14
heating	Capacity	Btu/h	40000.00	46000.00	55000.00
	HSPF (AHRI Certified)	Btu/h. W	8.30	8.30	8.30
Max. input consumption		W	4480.00	5043.75	6658.75
Max. current		A	20.50	23.08	30.47
Compressor	Brand		LG	LG	LG
	Model		ABG036KAC	ABG042KAC	ABG051KAC
	Type		scroll	scroll	scroll
	Capacity	W	10551	12309	14974
	Input	W	3429	3962	4722
	Rated current(RLA)	A	15.2	17.3	21.0
	Locked rotor Amp(LRA)	A	112	108	128
	Thermal protector	uf	45	70	70
Refrigerant oil	ml	1280	1280	1280	
Outdoor fan motor	Brand		chigo	xinjun	xinjun
	Model		S.TB-DQ-YDK-110-8P2-A L	S.TB-DQ-YDK-230-6P2	S.TB-DQ-YDK-230-6P2
	Input	W	207	510	510
	Output	W	110	230	230
	Capacitor	µF	6.00	12.00	12.00
	Speed	rpm	850	1095	1095
Outdoor coil	Number of row		2	2	2.7
	Fin spacing	in	0.055	0.055	0.055
	Fin material		Hydrophilic Aluminium Fin	Hydrophilic Aluminium Fin	Hydrophilic Aluminium Fin
	Tube outside diameter	in	Φ 0.276	Φ 0.276	Φ 0.276
	Tube material		Inner Grooved	Inner Grooved	Inner Grooved
	Coil length x height x width	in	84.65×31.48×1.05	84.65×31.48×1.05	84.65×31.48×1.05
	Number of circuit		10	10	8
Outdoor air flow		CFM	1562/1385/1208	1695/1574/1434	1695/1574/1434
Outdoor noise level		dB(A)	63	63	63
Outdoor dimension	Unit (WxHxD)	in	29×29×33	29×29×33	29×29×33
	Packing (WxHxD)	in	30×30×34	30×30×34	30×30×34
Refrigerant	Type		R410A	R410A	R410A
	Charge	ozs	141.09	148.15	190.48
Refrigerant pipe	Liquid side	in	Φ3/8	Φ3/8	Φ3/8
	Gas side	in	Φ3/4	Φ3/4	Φ7/8
	Max. refrigerant pipe length	ft	65 3964	65 3964	65 3964
	Max. difference in level	ft	32 13/16	32 13/16	32 13/16
Design pressure		MPa	4.0/1.2	4.0/1.2	4.0/1.2
Max pressure		MPa	4.20	4.20	4.20

2 .Dimensions

All dimensions are in mm. They are subject to change without notice. Certified dimensions will be provided upon request.

Unit Model	Dimensions(mm)			Refrigerant Connection Line Size(mm)			
	A	B	C	Liquid(Φ)		Vapor(?)	
				LF	RF	LF	RF
18	633	554	554	9.52		19.05	
24	633	554	554				
30	633	740	740				
36	633	740	740				
42	835	740	740				
48	835	740	740				
60	835	740	740			22	

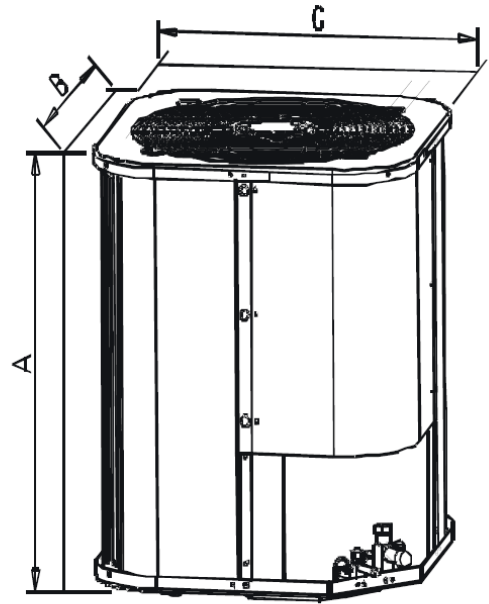

NOTE: LF means cooling only model; RF means heat pump model.

3. Service Space

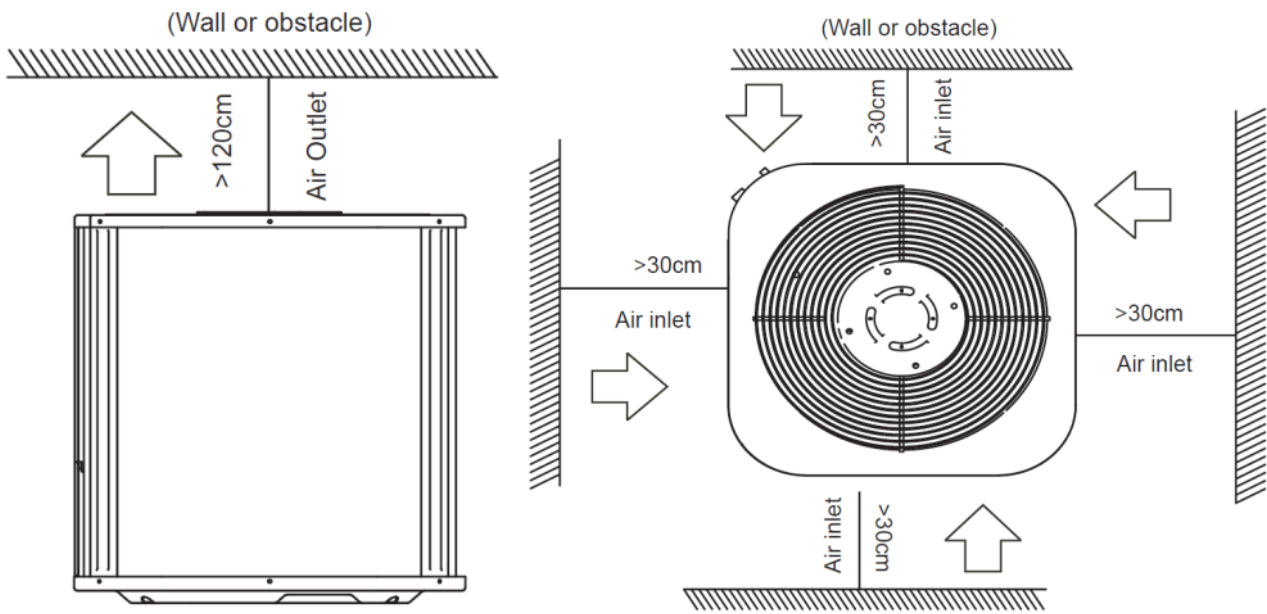

TYPICAL INSTALLATION

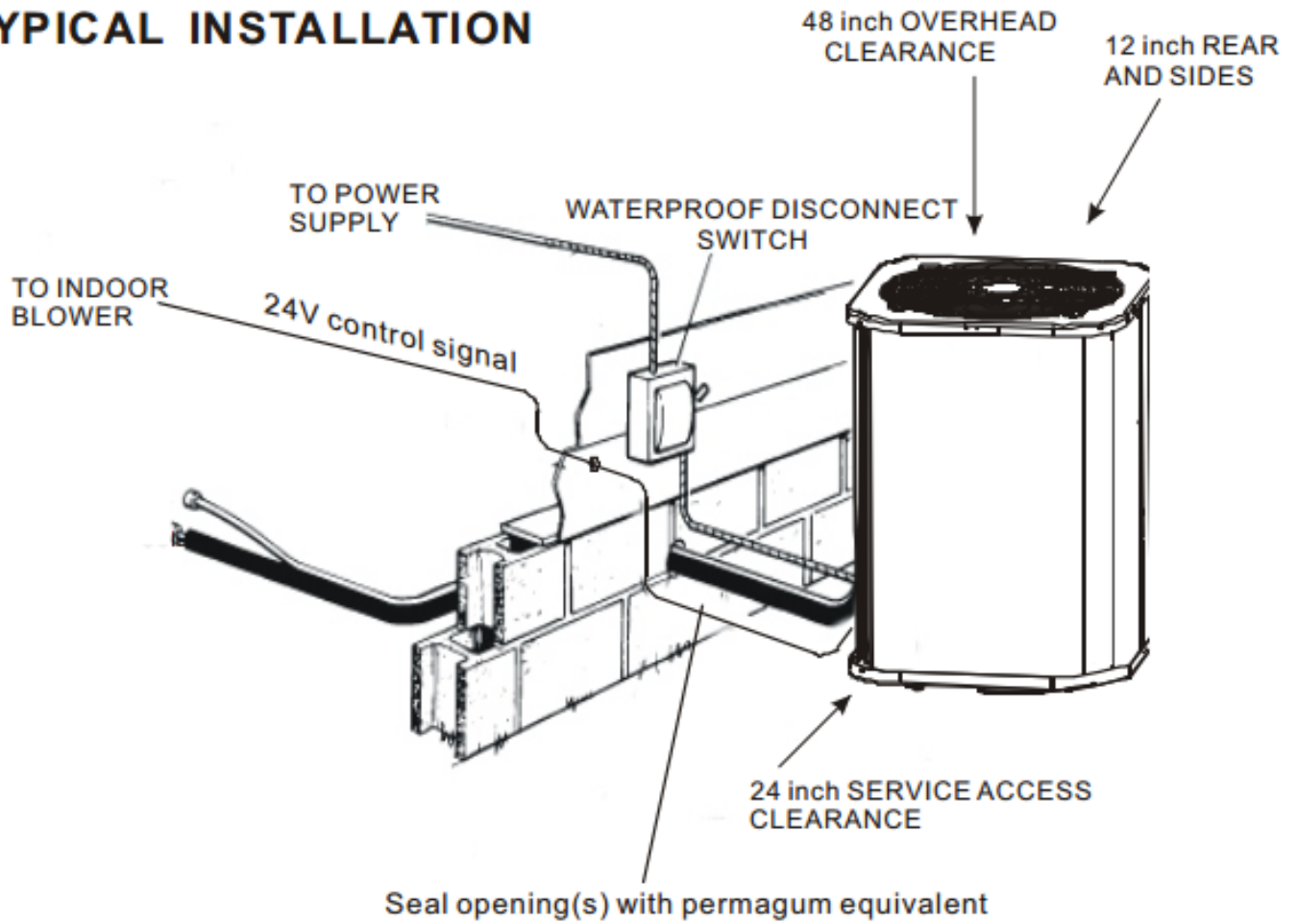

4. Wiring Diagrams

SEER 14 Cooling only

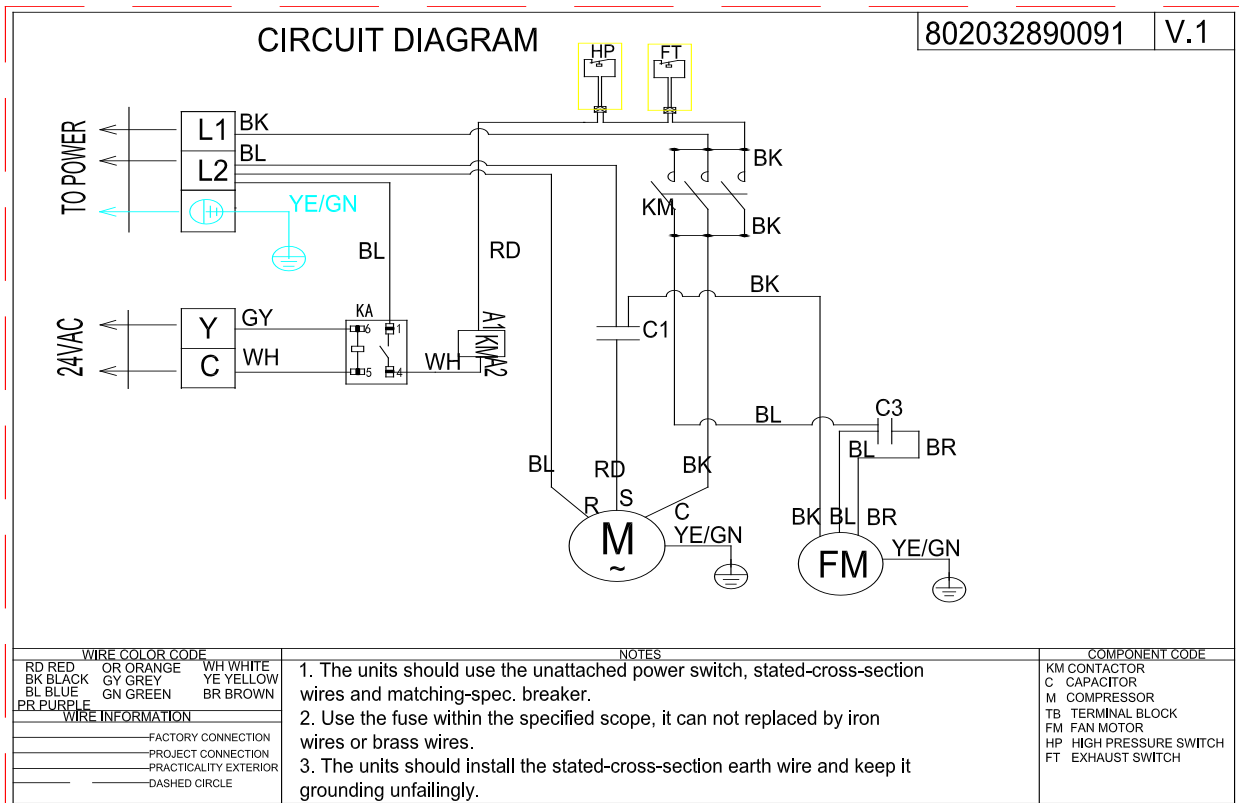

SEER 14 Heat pump

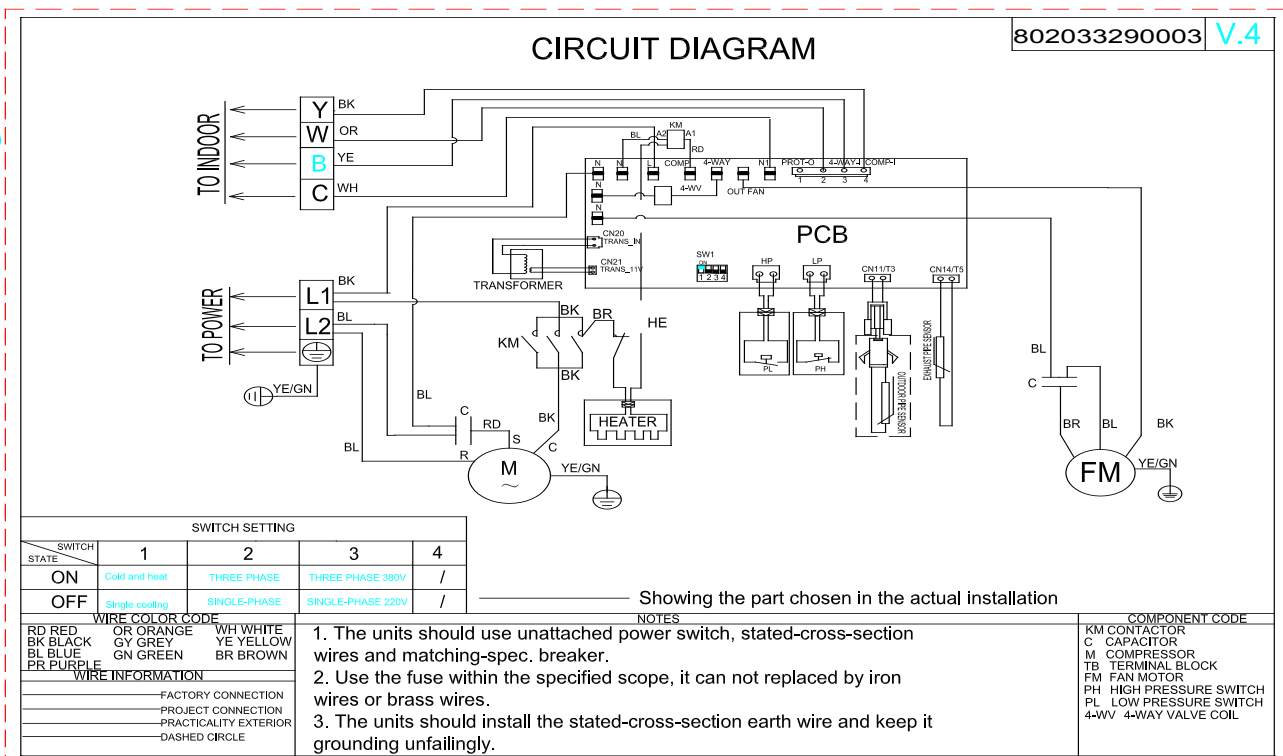

5. Electric Characteristics

Model	Outdoor Unit				
	Hz	Voltage	Min.	Max.	Outdoor motor (kw)
CTV14CN018A	60	208~230V	198V	242V	0.15
CTV14CN024A	60	208~230V	198V	242V	0.18
CTV14CN030A	60	208~230V	198V	242V	0.21
CTV14CN036A	60	208~230V	198V	242V	0.21
CTV14CN042A	60	208~230V	198V	242V	0.21
CTV14CN048A	60	208~230V	198V	242V	0.51
CTV14CN060A	60	208~230V	198V	242V	0.51

6. Operation Limits

Operation mode	Outdoor temperature(°C)	Room temperature(°C)
Cooling operation	18~43	17~30
Heating operation	-7~24	17~30

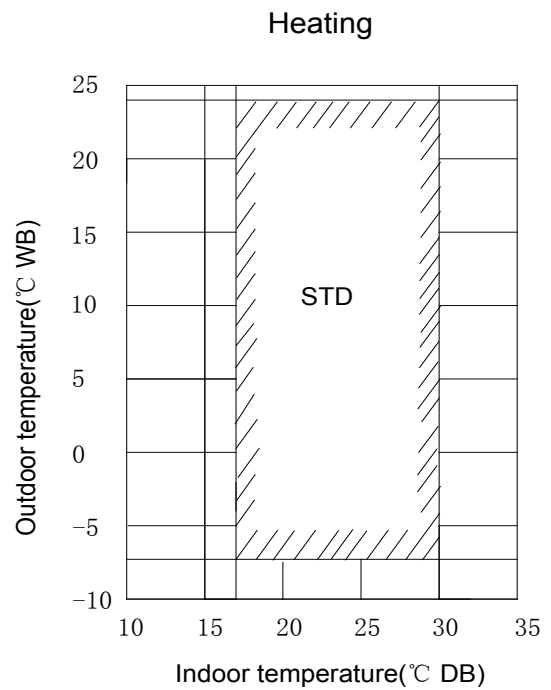
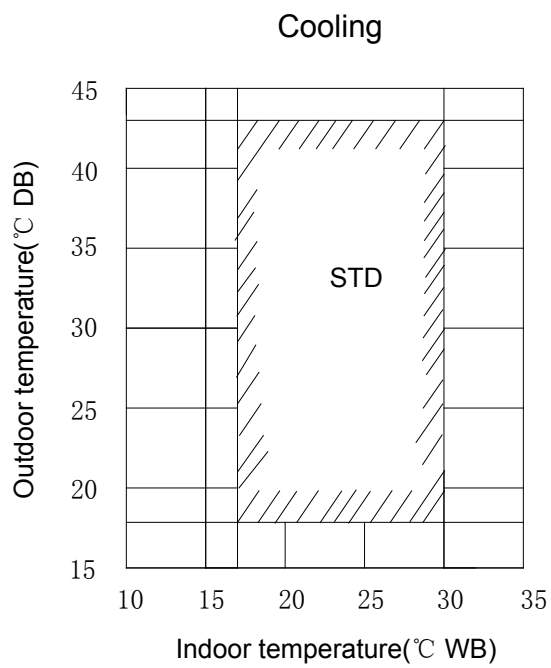

7. Sound Levels

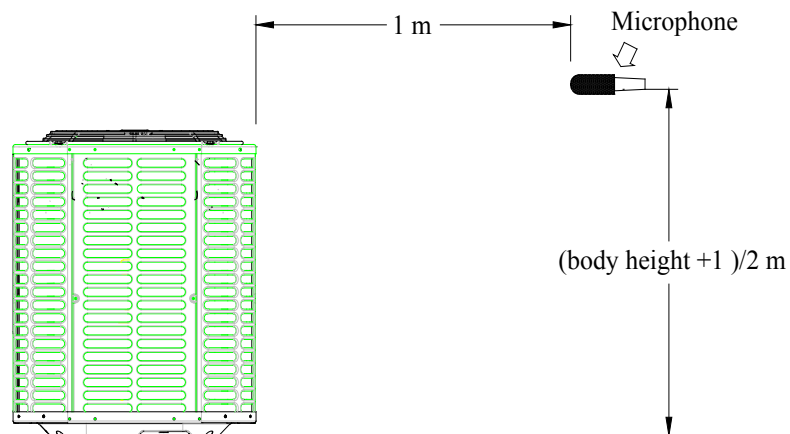

Model	Noise level dB(A)
CTV14CN018A	57
CTV14CN024A	56
CTV14CN030A	60
CTV14CN036A	60
CTV14CN042A	60
CTV14CN048A	63
CTV14CN060A	63

Note: Sound level is measured at a point 1 m in front of the unit, at a height of $(\text{Unit body height} + 1) / 2$ m.

8. Exploded View

8.1 Cooling Only

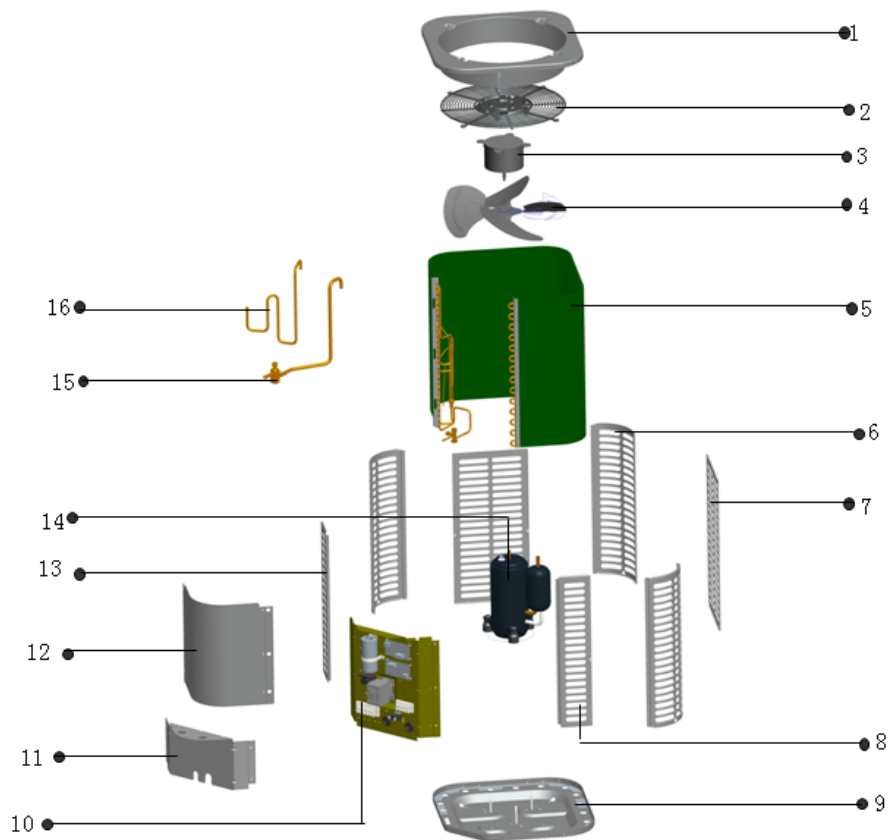

No.	Part Name	Quantity
1	Top cover assembly	1
2	Top net cover	1
3	Indoor motor	1
4	Propeller fan	1
5	Condenser component	1
5.1	Condenser assembly	1
5.2	Inlet pipe for condenser	1
5.3	Outlet pipe for condenser	1
5.4	Weld assembly for high temperture valve	1
5.4.1	Block valve body	1
6	Supporting board	3
7	Rear separating board	2
8	Right separating board	1
9	Chassis assembly	1

10	E-part component	1
10.1	Weld assembly for e-part mounting plate	1
10.2	Waterproof box for e-part	2
10.3	Terminal	1
10.4	Contactora	1
10.5	Compressor capacitor	1
10.6	Fan capacitor	1
11	Bottom separating board	1
12	Upper separating board	1
13	Left separating board	1
14	Compressor	1
15	Low pressure valves welding components	1
15.1	Block valve body	1
16	Discharge pipe	1

8.2 Heat Pump

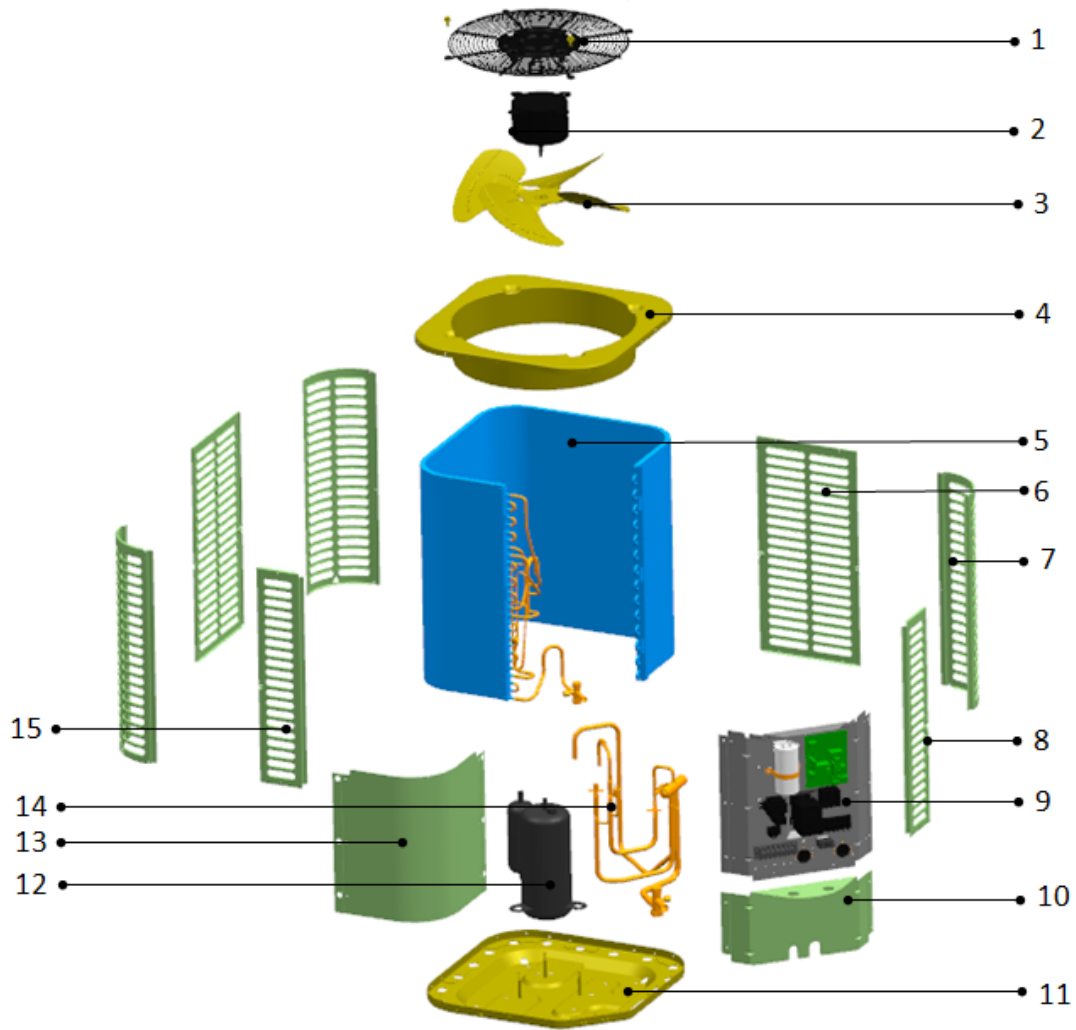

No.	Part Name	Quantity
1	Cover net	1
2	Outdoor motor	1
3	Axial-flow fan	1
4	Top cover assembly	1
5	Condenser assembly	1
5.1	Condenser	1
5.2	Condenser input pipe assembly	1
5.3	Condenser output pipe assembly	1
5.3.1	High-pressure valves weld assembly	1
5.3.1.1	S.TL-ZL-FTF-A02	1
6	Rear side-panel	2
7	Support board	3
8	Right side panel	1

9	Electronic components	1
9.1	Electric install board weld assembly	1
9.2	Terminal board	1
9.3	Terminal board	1
9.4	Contactactor	1
9.5	Fan capacitor	1
9.6	Compressor capacitor	1
9.7	Transformer	1
9.8	Electronic control box	1
10	Left side panel	1
11	Chassis assembly	1
12	Compressor	1
13	Top panel	1
14	Four way valve welding assembly	1
14.1	Four way valve	1
14.2	S.TL-ZL-FTF-A08	1
14.3	Pressure switch	1
15	Left side panel	1

9. Troubleshooting

The fault codes for outdoor unit as follows:

	Display contents	Status description
No alarm : Green light flashing Yellow light off	Green light slow flashing	normal standby
	Green light fast flashing	operating
System alarm : Green light always on Yellow light flashing	T3 sensor failure	Green light flashes 2 times every 5 seconds
	T5 sensor failure	
	Low voltage alarm	Green light flashes 6 times every 5 seconds
	High voltage alarm	Green light flashes 1 times every 5 seconds
	System overcurrent	Green light flashes 3 times every 5 seconds
	Phase sequence detection failure	Green light flashes 4 times every 5 seconds
	T3 high temperature protection	
	High exhaust temperature protection	Green light flashes 5 times every 5 seconds
	485 communication failure (keep)	
	Fan feedback failure	Green light flashes 7 times every 5 seconds
System lock : Green light off Yellow light always on	High/low voltage protection happen 3 times in 20 minutes	
	High exhaust temperature protection happen 3 times in 20 minutes	
	Overcurrent protection happen 3 times in 20 minutes	

Part 4 Installation

1 .Precaution on Installation	42
2. Vacuum Dry and Leakage Checking	43
3. Additional Refrigerant Charge	45
4. Insulation Work.....	46
5. Test Operation	48

1. Precaution on Installation

1.1. Measure the necessary length of the connecting pipe, and make it by the following way.

- a. Connect the indoor unit at first, then the outdoor unit.
Bend the tubing in proper way. Do not harm them.

CAUTIONS:

- Daub the surfaces of the flare pipe and the joint nuts with frozen oil, and wrench it for 3~4 rounds
- With hands before fasten the flare nuts.

Be sure to use two wrenches simultaneously when you connect or disconnect the pipes.

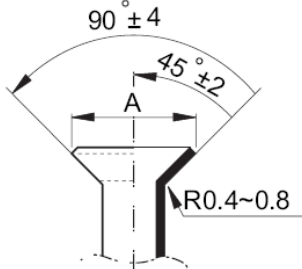
Pipe gauge	Tightening torque	Flare dimension A		Flare shape
		Min (mm)	Max	
Φ6.35	15~16N.m (153~163 kgf.cm)	8.3	8.7	
Φ9.52	25~26N.m (255~265kgf.cm)	12.0	12.4	
Φ12.7	35~36N.m (357~367kgf.cm)	15.4	15.8	
Φ15.9	45~47N.m (459~480 kgf.cm)	18.6	19.1	
Φ19.1	65~67N.m (663~684kgf.cm)	22.9	23.3	

- b. The stop value of the outdoor unit should be closed absolutely (as original state). Every time you connect it, first loosen the nuts at the part of stop value, then connect the flare pipe immediately (in 5 minutes). If the nuts have been loosened for a long time, dusts and other impurities may enter the pipe system and may cause malfunction later. So please expel the air out of the pipe with refrigerant before connection.
- c. Expel the air after connecting the refrigerant pipe with the indoor unit and the outdoor unit. Then fasten the nuts at the repair-points.

1.2. Locate The Pipe

- a. Drill a hole in the wall (suitable just for the size of the wall conduit), then set on the fittings such as the wall conduit and its cover.
- b. Bind the connecting pipe and the cables together tightly with binding tapes. Do not let air in, which will cause water leakage by condensation.
- c. Pass the bound connecting pipe through the wall conduit from outside. Be careful of the pipe allocation to do no damage to the tubing.

1.3. Connect the pipes.

1.4. Then, open the stem of stop values of the outdoor unit to make the refrigerant pipe connecting the indoor unit with the outdoor unit in fluent flow.

1.5. Be sure of no leakage by checking it with leak detector or soap water.

1.6. Cover the joint of the connecting pipe to the indoor unit with the soundproof / insulating sheath (fittings), and bind it well with the tapes to prevent leakage.

2. Vacuum Dry and Leakage Checking

2.1 Vacuum Dry: use vacuum pump to change the moisture (liquid) into steam (gas) in the pipe and discharge it out of the pipe to make the pipe dry. Under one atmospheric pressure, the boiling point of water(steam temperature) is 100°C. Use vacuum pump to make the pressure in the pipe near vacuum state, the boiling point of water falls relatively. When it falls under outdoor temperature, the moisture in the pipe will be vaporized.

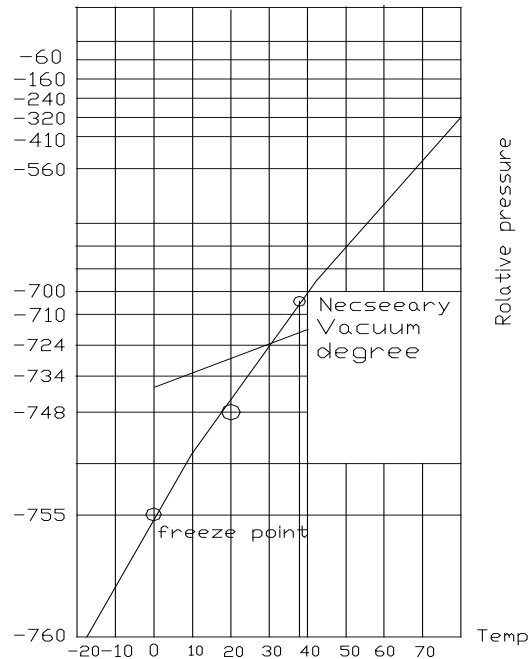

2.2 Vacuum dry procedure

There are two methods of vacuum dry due to different construction environment: common vacuum dry, special vacuum dry.

①. Common vacuum dry procedure

- Vacuum dry (for the first time)---connect the all-purpose detector to the inlet of liquid pipe and gas pipe, and run the vacuum pump more than two hours (the vacuum pump should be below -755mmHg)
- If the pump can't achieve below -755mmHg after pumping 2 hours, moisture or leakage point will still exist in the pipe. At this time, it should be pumped 1 hour more.
- If the pump can't achieve -755mmHg after pumping 3 hours, please check if there are some leakage points.
- Vacuum placement test: place 1 hour when it achieves -755mmHg, pass if the vacuum watch shows no rising. If it rises, it shows there's moisture or leakage point.
- Vacuuming from liquid pipe and gas pipe at the same time.
- Sketch map of common vacuum dry procedure.

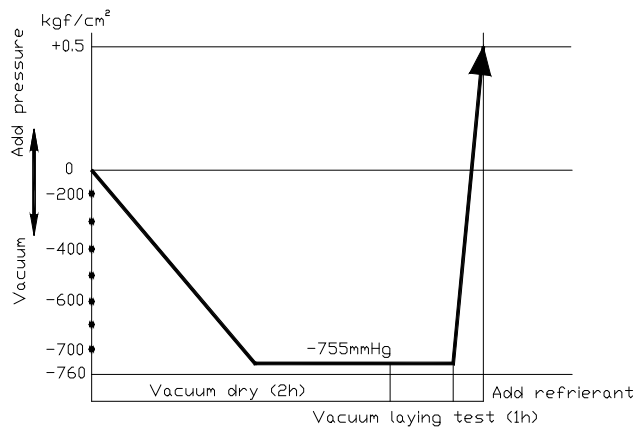

②. Special vacuum dry procedure

- This vacuum dry method is used in the following conditions:
- There's moisture when flushing the refrigerant pipe.
- Rainwater may enter into the pipe.
- Vacuum dry for the first time 2h pumping

③. Vacuum destroy for the second time Fill nitrogen to 0.5Kgf/cm²

Because nitrogen is for drying gas, it has vacuum drying effect during vacuum destroy. But if the moisture is too much, this method can't dry thoroughly. So, please pay more attention to prevent water entering and forming condensation water.

④. Vacuum dry for the second time 1h pumping

Determinant: Pass if achieving below -755mmHg. If -755mmHg can't be achieved in 2h, repeat procedure

③ and ④.

⑤. Vacuum placing test 1h

⑥. Sketch map of special vacuum dry procedure

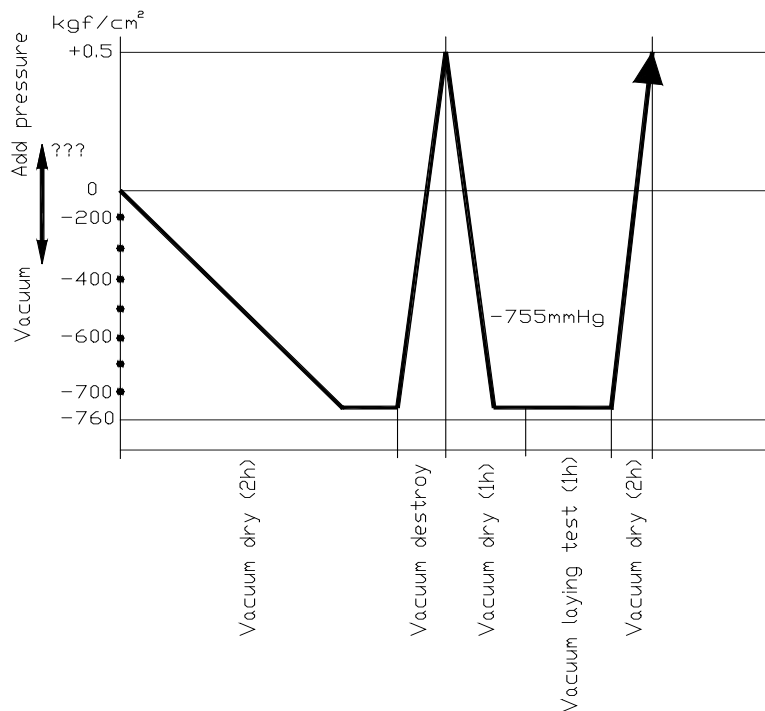

3. Additional Refrigerant Charge

Caution

- Refrigerant cannot be charged until field wiring has been completed.
- Refrigerant may only be charged after performing the leak test and the vacuum pumping.
- When charging a system, care shall be taken that its maximum permissible charge is never exceeded, in view of the danger of liquid hammer.
- Charging with an unsuitable substance may cause explosions and accidents, so always ensure that the appropriate refrigerant is charged.
- Refrigerant containers shall be opened slowly.
- Always use protective gloves and protect your eyes when charging refrigerant.

The outdoor unit is factory charged with refrigerant. Calculate the added refrigerant according to the diameter and the length of the liquid side pipe of the outdoor unit/indoor unit

R(g) \ D(mm)	φ6.35	φ9.52	φ12.7
L(m)			
Less than 5m (One-way)	—	—	—
Added Refrigerant When Over 5m(One-way)	20g/m×(L-5)	40g/m×(L-5)	60g/m×(L-5)

Remark:

R (g): Additional refrigerant to be charged

L (m): The length of the refrigerant pipe (one-way)

D (mm): Liquid side piping

4. Insulation Work

4.1 Insulation material and thickness

4.1.1. Insulation material

Insulation material should adopt the material which is able to endure the pipe's temperature: no less than 70°C in the high-pressure side, no less than 120°C in the low-pressure side (For the cooling type machine, no requirements at the low-pressure side.)

- ◆ Example: Heat pump type----Heat-resistant Polyethylene foam (withstand above 120°C)
Cooling only type----Polyethylene foam (withstand above 100°C)

4.1.2. Thickness choice for insulation material

Insulation material thickness is as follows:

	Pipe diameter (mm)	Adiabatic material thickness
Refrigerant pipe	Φ6.4—Φ25.4	10mm
	Φ28.6—Φ38.1	15mm
Drainage pipe	Inner diameterΦ20—Φ32	6mm

4.2 Refrigerant pipe insulation

4.2.1. Work Procedure

- ① Before laying the pipes, the non-jointing parts and non-connection parts should be heat insulated.
- ② When the gas proof test is eligible, the jointing area, expanding area and the flange area should be heat insulated.

4.2.2. Insulation for non-jointing parts and non-connection parts

wrong	right	
Gas pipe and liquid pipe should not be put together to insulate	Insulate the gas pipe (cooling only)	Insulate the gas pipe and liquid pipe

For construction convenience, before laying pipes, use insulation material to insulate the pipes to be deal with, at the same time, at two ends of the pipe, remain some length not to be insulated, in order to be welded and check the leakage after laying the pipes.

4.2.3. Insulate for the jointing area, expanding area and the flange area

- ① Insulate for the jointing area, expanding area and the flange area should be done after checking leakage of the pipes
- ② Make sure there's no clearance in the joining part of the accessorial insulation material and local preparative insulation material.

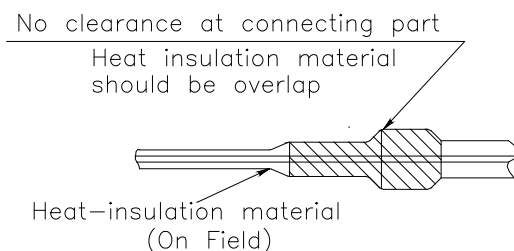

4.3 Drainage pipe insulation

The connection part should be insulated, or else water will be condensing at the non-insulation part.

4.4 Note

5.4.1 The jointing area, expanding area and the flange area should be heat insulated after passing the pressure test.

4.4.2 The gas and liquid pipe should be heat insulated individually, the connecting part should be heat insulated individually.

4.4.3 Use the attached heat-insulation material to insulate the pipe connections (pipes' tie-in ,expand nut) of the indoor unit.

5. Test Operation

(1) The test operation must be carried out after the entire installation has been completed.

(2) Please confirm the following points before the test operation.

- The indoor unit and outdoor unit are installed properly.
- Tubing and wiring are correctly completed.
- The refrigerant pipe system is leakage-checked.
- The drainage is unimpeded.
- The ground wiring is connected correctly.
- The length of the tubing and the added stow capacity of the refrigerant have been recorded.
- The power voltage fits the rated voltage of the air conditioner.
- There is no obstacle at the outlet and inlet of the outdoor and indoor units.
- The gas-side and liquid-side stop valves are both opened.
- The air conditioner is pre-heated by turning on the power.

(3) According to the user's requirement, install the remote controller when the remote controller's signal can reach the indoor unit smoothly.

(4) Test operation

Set the air conditioner under the mode of "COOLING" with the remote controller, and check the following points.

Indoor unit

- Whether the switch on the remote controller works well.
- Whether the buttons on the remote controller works well.
- Whether the air flow louver moves normally.
- Whether the room temperature is adjusted well.
- Whether the indicator lights normally.
- Whether the temporary buttons works well.
- Whether the drainage is normal.
- Whether there is vibration or abnormal noise during operation.

Outdoor unit

- Whether there is vibration or abnormal noise during operation.
- Whether the generated wind, noise, or condensed of by the air conditioner have influenced your neighborhood.
- Whether any of the refrigerant is leaked.